

## DESCRIPTION

The PM500F series of AC-DC switching power supplies in a package of 3.98 x 7.09 x 1.56 inches are capable of delivering 450-500 watts of continuous power at 30 CFM forced air cooling or 250 watts at convection cooling. The units are constructed on a printed circuit board with a U-bracket for mechanical support and heat sinking. A cover and fan assembly can be added during manufacturing.

## FEATURES

- BF Class insulation
- The PM500F model is designed for Home Health Care application
- Class II application
- Operation altitude up to 5000 meters
- 80-264 VAC input with active PFC
- Less than 100  $\mu$ A leakage current
- EN55011 Class B conducted emissions
- Inhibit - TTL high to disable output
- Compliant with RoHS requirements
- Power consumption in standby mode less than 1W at standby power 5 V /100 mA

## INPUT SPECIFICATIONS

Input voltage:	80-264 VAC
Power derating:	Derate linearly from 100% at 90 VAC to 90% at 85 VAC and 80% at 80 VAC
Input frequency:	47-63 Hz
Input current:	5.2 A (rms) @ 115 VAC, 60 Hz 2.6 A (rms) @ 230 VAC, 50 Hz
Touch current:	100 $\mu$ A max. @ 264 VAC, 63 Hz

## OUTPUT SPECIFICATIONS

Output voltage/current:	See rating chart.
Maximum output power:	See rating chart.
Ripple and noise:	1% peak to peak maximum
Remote sense:	Compensation for cable losses up to 0.5V
Over power protection:	Set at 105-140% of its maximum output power, Automatic recovery
Over voltage protection:	Set at 112-140% of its rated output voltage, latching by recycle input to reset
Over temperature protection:	Latching by recycle input to reset
Short circuit protection:	Automatic recovery
Temperature coefficient:	All outputs $\pm 0.04\%$ / $^{\circ}$ C maximum
Transient response:	Maximum excursion of 4%, recovering to 1% of final value within 500 us after a 25% step load change
Standby power:	5 V at 2 A maximum
Fan power:	12 V at 300 mA maximum

## ENVIRONMENTAL SPECIFICATIONS

Operating temperature:	-10 $^{\circ}$ C to +70 $^{\circ}$ C
Storage temperature:	-40 $^{\circ}$ C to +85 $^{\circ}$ C
Relative humidity:	5% to 95% non-condensing
Temperature derating:	Derate from 100% at +50 $^{\circ}$ C linearly to 50% at +70 $^{\circ}$ C, applicable to convection and forced-air cooling conditions

## PM500F SERIES



## SAFETY STANDARD APPROVALS



UL ES 60601-1, CSA C22.2 No. 60601-1  
File No. E178020



TÜV EN 60601-1

## GENERAL SPECIFICATIONS

Switching frequency:	55-300 KHz
Efficiency:	Typical 92%
Hold-up time:	20 ms minimum at 110 VAC & 250 W
Line regulation:	$\pm 0.5\%$ maximum at full load
Inrush current:	30 A @ 115 VAC, or 60 A @ 230 VAC, at 25 $^{\circ}$ C cold start
Withstand voltage:	4000 VAC from input to output (2 MOPP) 4000 VAC from input to case (2 MOPP) 1500 VAC from output to case (1 MOPP)
MTBF:	100,000 hours at full load at 25 $^{\circ}$ C ambient, calculated per MIL-HDBK-217F
EMC Performance (EN60601-1-2)	
EN55011:	Class B conducted, class B radiated
EN61000-3-2:	Harmonic distortion, class A and D
EN61000-3-3:	Line flicker
EN61000-4-2:	ESD, $\pm 15$ KV air and $\pm 8$ KV contact
EN61000-4-3:	Radiated immunity, 9-28 V/m
EN61000-4-4:	Fast transient/burst, $\pm 2$ KV
EN61000-4-5:	Surge, $\pm 1$ KV diff.
EN61000-4-6:	Conducted immunity, 10 Vrms
EN61000-4-8:	Magnetic field immunity, 30 A/m
EN61000-4-11:	Voltage dip immunity, 30% reduction for 500 ms and 100% reduction for 10 ms

## INTERFACE SIGNALS

PFD:	TTL high for normal operation, low upon loss of input power, turn-on delay time 100-1000 ms, turn-off delay time 1 ms minimum
Inhibit:	Requires an external TTL high level signal to inhibit outputs for standard models

## OUTPUT POWER DERATING CURVE

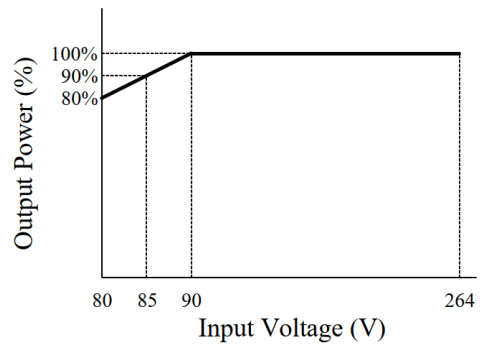
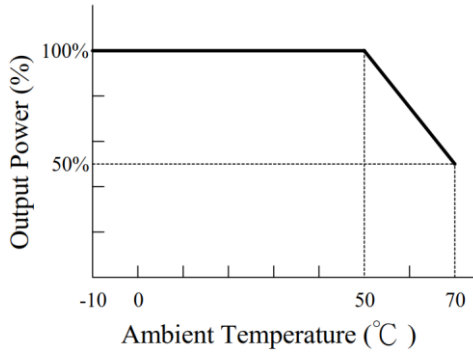

## OUTPUT VOLTAGE/CURRENT RATING CHART

Model <sup>(1)</sup>	Output							Efficiency (typical) 115 /230 Vac
	Class II	V1	Min. Current	Max. Current at convection	Max. Current at 30 CFM	Tol.	Ripple & Noise <sup>(3)</sup>	
PM500F-12A	12 V	0 A	20.83 A	37.50 A	±2%	120 mV	250 W /450 W	89 /91%
PM500F-13A	15 V	0 A	16.67 A	30.00 A	±2%	150 mV	250 W /450 W	89 /91%
PM500F-13-1A	18 V	0 A	13.89 A	27.78 A	±2%	180 mV	250 W /500 W	89 /91%
PM500F-14A	24 V	0 A	10.42 A	20.84 A	±2%	240 mV	250 W /500 W	90 /92%
PM500F-15A	28 V	0 A	8.93 A	17.86 A	±2%	280 mV	250 W /500 W	90 /92%
PM500F-16A	30 V	0 A	8.34 A	16.67 A	±2%	300 mV	250 W /500 W	90 /92%
PM500F-17A	36 V	0 A	6.94 A	13.89 A	±2%	360 mV	250 W /500 W	90 /92%
PM500F-18A	48 V	0 A	5.21 A	10.42 A	±2%	480 mV	250 W /500 W	90 /92%
PM500F-19A	57 V	0 A	4.38 A	8.78 A	±2%	570 mV	250 W /500 W	90 /92%

### NOTES:

- Suffix "A" in models denotes PCB form; change suffix to "B" for U-Bracket form, e.g. PM500F-14B; change suffix "C" for enclosed cover and fan assembly, e.g. PM500F-14C.
- 250 W without moving air or 450-500 W with 30 CFM forced air provided by user for "A" and "B" versions, 450-500W for "C" version with cover and fan assembly.
- Ripple and noise is maximum peak-to-peak voltage value measured at output within 20 MHz bandwidth, at rated line voltage and output load ranges, and with a 10 µF tantalum capacitor in parallel with a 0.1 µF ceramic capacitor across the output.

## MECHANICAL SPECIFICATIONS

### PCB Form

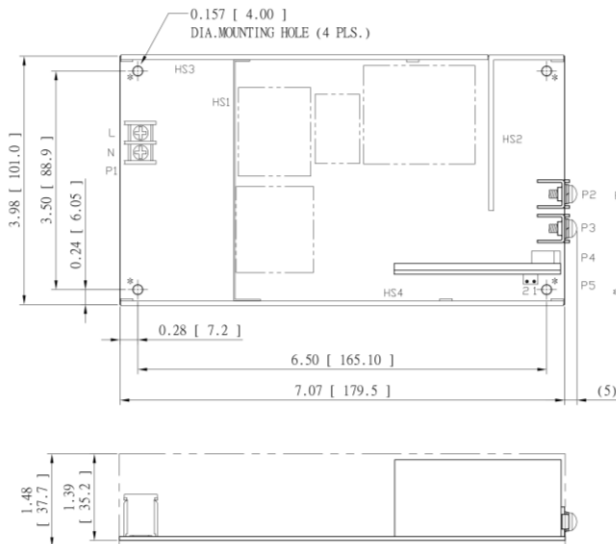

### U-bracket Form

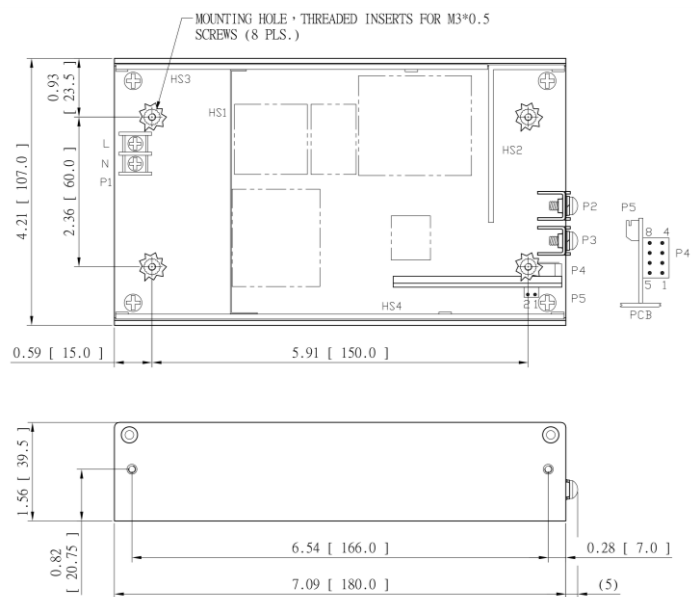

## Enclosed form

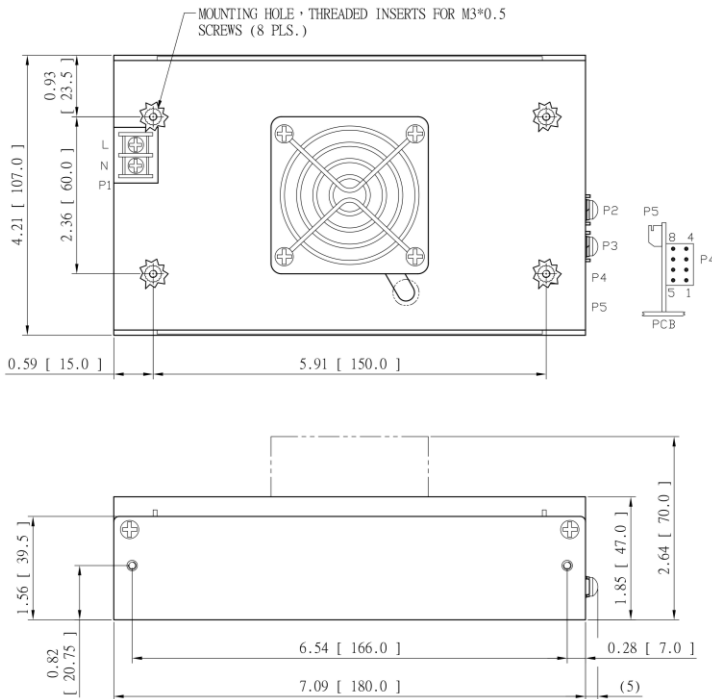

### NOTES:

1. Dimensions shown in inches [mm]
2. Tolerance 0.02 [0.5] maximum
3. Input connector P1 is Dinkle terminal P/N DT-35C-B01W-02, with nickel plated M3 screws.
4. Output connectors P2 and P3 are for M4x0.7 screw connections.
5. Output connector P4 is Molex header 87833-08 or equivalent, mating with Molex housing 51110-0851 or equivalent.
6. Fan connector P5 is JST header B2B-ZR-3.4 or equivalent, mating with JST housing ZHR-2 or equivalent.
7. To ensure compliance with level B emissions, connect the four "\*" marked mounting holes with metallic standoffs to chassis.
8. Weight: 1.0 Kg (2.23 lbs.) approx. for U-bracket form, 1.14 Kgs. (2.52 lbs.) approx. for enclosed form
9. Maximum penetration of fixing screws is 4 mm from the outer surface of chassis.

### PIN CHART

PIN NO.	P1 (AC)		P2	P3	P5	
	1	2			1	2
<b>Polarity</b>	Live	Neutral	+V1	Common Return	Common Return	+12V Fan

PIN NO.	P4							
	1	2	3	4	5	6	7	8
<b>Polarity</b>	Common Return	+V1 Sense	-V1 Sense	PFD	Inhibit	+5V Standby	+5V Standby	Common Return