

## DESCRIPTION

The PM300 series comprising single and multiple output models for 200-300 watts of continuous output power is specially designed for medical and ITE applications, not for life-supporting equipment. They operate at 90-264 VAC input voltage without the need of a selector strap. All auxiliary outputs are with magnetic amplifier to keep regulation. The units are constructed on a printed circuit board with a U-bracket for mechanical support and heat sinking. A cover-and-fan assembly can be added during manufacturing.

## FEATURES

- EN61000-3-2 class A and D compliant
- Power Factor 0.98 typical
- Overvoltage protection
- Short-circuit protection
- Power Fail Detect (PFD) signal
- 100% burn-in at full rated load
- Remote sense on output #1 and output #2
- Remote inhibit – TTL high to disable output
- Compliant with RoHS requirements

## INPUT SPECIFICATIONS

Input voltage:	90-264 VAC
Input frequency:	47-63 Hz
Input current:	4.7 A (rms) for 115 VAC 2.3 A (rms) for 230 VAC
Earth leakage current:	300 $\mu$ A max. @ 264 VAC, 63 Hz

## OUTPUT SPECIFICATIONS

Output voltage/current:	See rating chart.
Maximum output power:	See rating chart.
Ripple and noise:	1% peak to peak maximum
Overvoltage protection:	Provided on output #1 only; set at 115-140% of its nominal output voltage
Overcurrent protection:	All outputs protected to short circuit conditions
Temperature coefficient:	All outputs $\pm 0.04\%$ / $^{\circ}$ C maximum
Transient response:	Maximum excursion of 4% or better on all models, recovering to 1% of final value within 500 $\mu$ s after a 25% step load change
Fan power:	12 V at 350 mA maximum for B version, 12 V at 100 mA maximum for C version

## INTERFACE SIGNALS

PFD:	TTL logic high for normal operation and TTL logic low upon loss of input power. This signal appears at least 1 ms prior to master output dropping 5% below its nominal value. This signal also provides a minimum delay of 100 ms after master output is within regulation.
Inhibit:	Requires an external TTL high level signal to inhibit outputs for standard models

## PM300 SERIES



**CE** (LVD)  
**RoHS**

## SAFETY STANDARD APPROVALS



UL 60601-1, CSA C22.2 No. 601.1  
File No. E178020

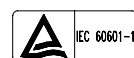

TÜV EN 60601-1



UL 60950-1, CSA C22.2 No. 60950-1  
File No. E137410



TÜV EN 60950-1

## ENVIRONMENTAL SPECIFICATIONS

Operating temperature:	0 $^{\circ}$ C to +70 $^{\circ}$ C
Storage temperature:	-40 $^{\circ}$ C to +85 $^{\circ}$ C
Relative humidity:	5% to 95% non-condensing
Derating:	Derate from 100% at +50 $^{\circ}$ C, linearly to 50% at +70 $^{\circ}$ C
Cooling:	200 /250 /300 watts continuous output power at 35 CFM forced air cooling or 100 /125 /150 watts at convention cooling

## GENERAL SPECIFICATIONS

Switching frequency:	70 KHz $\pm 10$ KHz
Power factor:	0.98 typical
Efficiency:	70% minimum on all models
Hold-up time:	12 ms minimum at 110 VAC
Line regulation:	$\pm 0.2\%$ maximum at full load
Inrush current:	30 A @ 115 VAC or 60A @ 230 VAC, at 25 $^{\circ}$ C cold start
Withstand voltage:	4000 VAC from input to output, 1500 VAC from input to ground, 500 VAC from output to ground
MTBF:	300,000 hours minimum at full load at 25 $^{\circ}$ C ambient, calculated per MIL-HDBK-217F
EMC Performance (EN60601-1-2)	
EN55011:	Class B conducted, Class B radiate
EN61000-3-2:	Harmonic distortion, Class A and D
EN61000-3-3:	Line flicker
EN61000-4-2:	ESD, $\pm 8$ KV air and $\pm 6$ KV contact
EN61000-4-3:	Radiated immunity, 3 V/m
EN61000-4-4:	Fast transient/burst, $\pm 2$ KV
EN61000-4-5:	Surge, $\pm 1$ KV diff., $\pm 2$ KV com.
EN61000-4-6:	Conducted immunity, 3 Vrms
EN61000-4-8:	Magnetic field immunity, 3 A/m
EN61000-4-11:	Voltage dip immunity, 30% reduction for 500 ms, 60% reduction for 100 ms and >95% reduction for 10 ms

## OUTPUT VOLTAGE/CURRENT RATING CHART

Model <sup>(1)(2)(6)</sup>	Output #1 <sup>(3)(5)</sup>				Output #2 <sup>(3)(5)</sup>				Output #3 <sup>(4)</sup>				Output #4 <sup>(4)</sup>				Max. Output Power <sup>(5)</sup>
	V1	Imin.	I <sub>max.</sub>	Tol.	V2	Imin.	I <sub>max.</sub>	Tol.	V3	Imin.	I <sub>max.</sub>	Tol.	V4	Imin.	I <sub>max.</sub>	Tol.	
PM300-10-3B	3.3 V	3.0 A	60.0 A	±3%	(N/A)				(N/A)				(N/A)				100 W / 200 W
PM300-10B	5.1 V	3.0 A	60.0 A	±2%	(N/A)				(N/A)				(N/A)				150 W / 300 W
PM300-12B	12 V	1.2 A	25.0 A	±2%	(N/A)				(N/A)				(N/A)				150 W / 300 W
PM300-13B	15 V	1.0 A	20.0 A	±2%	(N/A)				(N/A)				(N/A)				150 W / 300 W
PM300-14B	24 V	0.6 A	12.5 A	±2%	(N/A)				(N/A)				(N/A)				150 W / 300 W
PM300-16B	30 V	0.5 A	10.0 A	±2%	(N/A)				(N/A)				(N/A)				150 W / 300 W
PM300-18B	48 V	0.5 A	6.3 A	±2%	(N/A)				(N/A)				(N/A)				150 W / 300 W
PM300-40-3B	3.3 V	3.0 A	35.0 A	±3%	5.1 V	2.0 A	22 A	±2%	12 V	0 A	4 A	±4%	12 V	0 A	4 A	±4%	125 W / 250 W
PM300-40B	5.1 V	2.0 A	35.0 A	±2%	12 V	1.0 A	10 A	±2%	12 V	0 A	4 A	±4%	5.1 V	0 A	4 A	±4%	150 W / 300 W
PM300-41B	5.1 V	2.0 A	35.0 A	±2%	15 V	0.8 A	8 A	±2%	15 V	0 A	4 A	±4%	24 V	0 A	2.5 A	±4%	150 W / 300 W
PM300-42B	5.1 V	2.0 A	35.0 A	±2%	12 V	1.0 A	10 A	±2%	12 V	0 A	4 A	±4%	12 V	0 A	4 A	±4%	150 W / 300 W
PM300-45B	5.1 V	2.0 A	35.0 A	±2%	12 V	1.0 A	10 A	±2%	12 V	0 A	4 A	±4%	24 V	0 A	2.5 A	±4%	150 W / 300 W
PM300-46B	5.1 V	2.0 A	35.0 A	±2%	12 V	1.0 A	10 A	±2%	12 V	0 A	4 A	±4%	15 V	0 A	4 A	±4%	150 W / 300 W
PM300-47B	5.1 V	2.0 A	35.0 A	±2%	24 V	0.5 A	5 A	±2%	12 V	0 A	4 A	±4%	12 V	0 A	4 A	±4%	150 W / 300 W
PM300-48B	5.1 V	2.0 A	35.0 A	±2%	24 V	0.5 A	5 A	±2%	5.1 V	0 A	4 A	±4%	15 V	0 A	4 A	±4%	150 W / 300 W
PM300-49B	5.1 V	2.0 A	35.0 A	±2%	12 V	1.0 A	10 A	±2%	5.1 V	0 A	4 A	±4%	24 V	0 A	2.5 A	±4%	150 W / 300 W
PM300-410B	24 V	0.5 A	6.3 A	±2%	12 V	1.0 A	10 A	±2%	5.1 V	0 A	4 A	±4%	12 V	0 A	4 A	±4%	150 W / 300 W
PM300-411B	24 V	0.5 A	6.3 A	±2%	12 V	1.0 A	10 A	±2%	5.1 V	0 A	4 A	±4%	24 V	0 A	2.5 A	±4%	150 W / 300 W
PM300-412B	24 V	0.5 A	6.3 A	±2%	12 V	1.0 A	10 A	±2%	12 V	0 A	4 A	±4%	12 V	0 A	4 A	±4%	150 W / 300 W
PM300-413B	24 V	0.5 A	6.3 A	±2%	24 V	0.5 A	5 A	±2%	5.1 V	0 A	4 A	±4%	15 V	0 A	4 A	±4%	150 W / 300 W
PM300-414B	24 V	0.5 A	6.3 A	±2%	24 V	0.5 A	5 A	±2%	12 V	0 A	4 A	±4%	12 V	0 A	4 A	±4%	150 W / 300 W

### NOTES:

- Suffix "B" in model numbers denotes U-bracket form. Change "B" to "C" for enclosed form with cover-and-fan assembly, e.g. PM300-45C.
- All outputs are floating. They can be connected externally for positive or negative output.
- Output #1 & #2 can be adjusted within ±5% of their nominal voltage.
- Output #3 & #4 can be adjusted within ±15% of their nominal voltage.
- 300 watts for "C" version with cover-and-fan assembly, 150 watts for "B" version without moving air (maximum current of output #1 & #2 derated to 50%), or 300 watts with 35 CFM forced air provided by user.
- PM300-10-3B is rated 200 watts with 35 CFM forced air cooling or 100 watts convection cooled. PM300-40-3B is rated 250 watts with 35 CFM forced air cooling (maximum current of output #1 & #2 derated to 50%) or 125 watts convection cooled.
- Single output models may be operated at no-load. At no-load, output voltage tolerance increases to ±10%.
- Ripple and noise is maximum peak-to-peak voltage value measured at output within 20 MHz bandwidth, at rated line voltage and output load ranges, and with a 10 μF tantalum capacitor in parallel with a 0.1 μF ceramic capacitor across the output.

### OUTPUT POWER DERATING CURVE

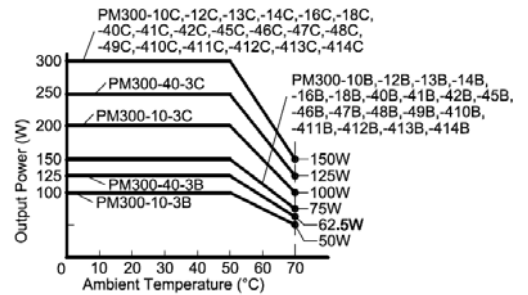

## MECHANICAL SPECIFICATIONS

### Single Output Models

#### U-bracket Form

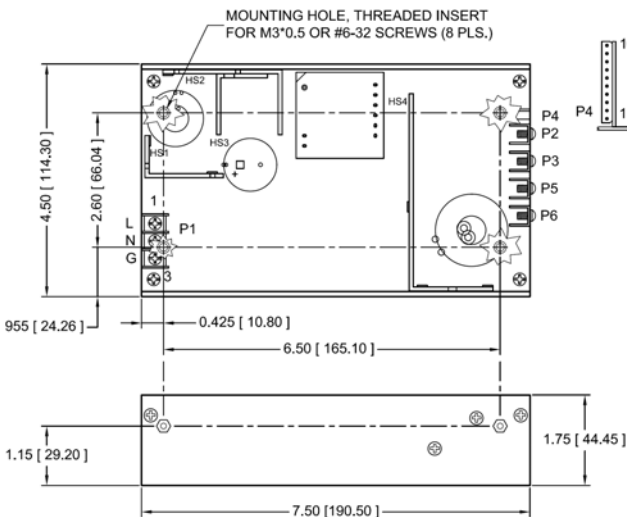

#### Enclosed Form

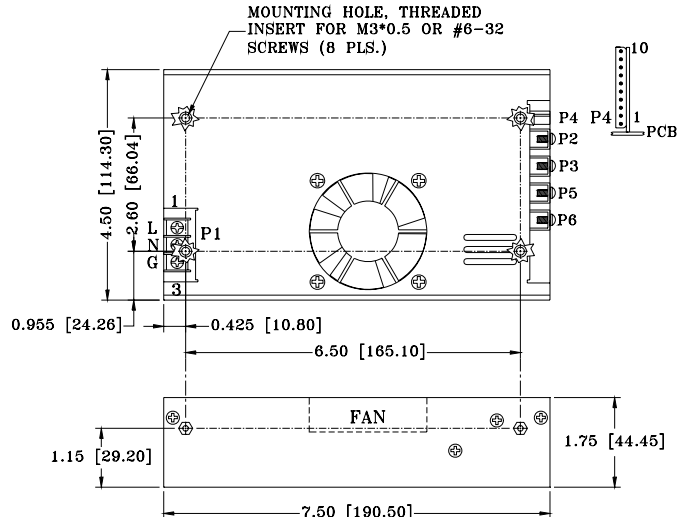

## Multiple Output Models U-bracket Form

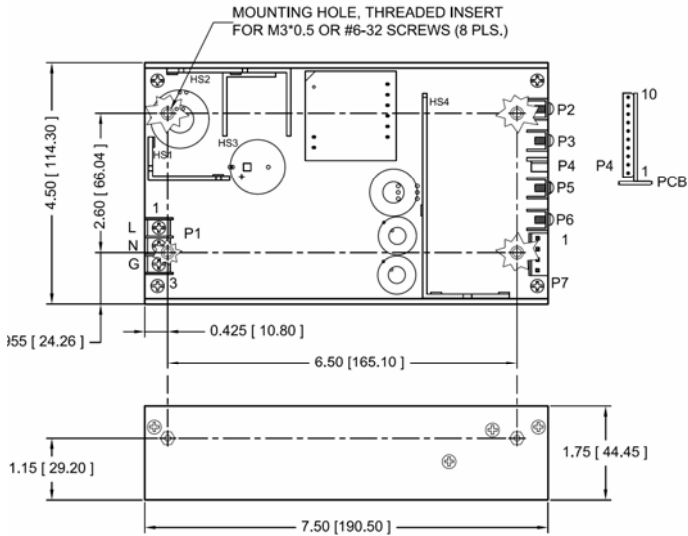

## Enclosed Form

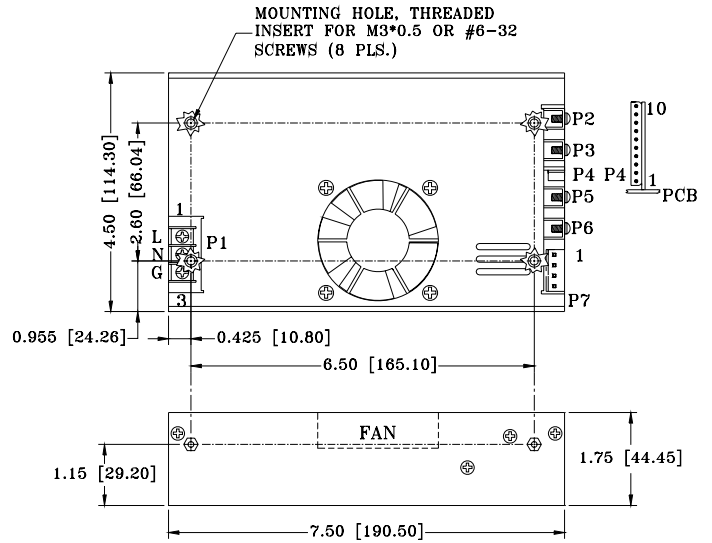

### NOTES:

1. Dimensions shown in inches [mm]
2. Tolerance 0.02 [0.5] maximum
3. Input connector P1 is Dinkle DT-35-B01W-03 with M3, nickel-plated screws.
4. Connector P4 mates with Molex housing 50-37-5103 and pins 5263.
5. Connectors P2, P3, P5 and P6: M3\*0.5 screw connections
6. Output connector P7 mates with Molex housing 09-50-3041 and Molex 2878 series crimp terminal.
7. Weight: 1.10 Kgs. (2.42 lbs.) approx. for U-bracket form, 1.24 Kgs. (2.73 lbs.) approx. for Enclosed form.
8. Maximum penetration depth of fixing screws is 4 mm from the outer surface of chassis.

### PIN CHART

MODEL	CONN PIN	P1 (AC)			P2	P3	P5	P6	P7			
		1	2	3					1	2	3	4
PM300-10-3B PM300-10B PM300-12B PM300-13B	PM300-14B PM300-16B PM300-18B	Live	Neutral	Ground	+V1		V1 Return	N.A.				
PM300-40-3B PM300-40B PM300-41B PM300-42B PM300-45B PM300-46B PM300-47B	PM300-48B PM300-49B PM300-410B PM300-411B PM300-412B PM300-413B PM300-414B	Live	Neutral	Ground	+V1	V1 Return	+V2	V2 Return	+V3	V3 Return	+V4	V4 Return

MODEL	CONN PIN	P4									
		1	2	3	4	5	6	7	8	9	10
PM300-10-3B PM300-10B PM300-12B PM300-13B	PM300-14B PM300-16B PM300-18B	Signal Common Return	+V1 Sense	-V1 Sense	PFD	Inhibit +V	N.C.	N.C.	N.C.	Fan Return	+12V Fan
PM300-40-3B PM300-40B PM300-41B PM300-42B PM300-45B PM300-46B PM300-47B	PM300-48B PM300-49B PM300-410B PM300-411B PM300-412B PM300-413B PM300-414B	Signal Common Return	+V1 Sense	-V1 Sense	PFD	Inhibit +V	N.C.	+V2 Sense	-V2 Sense	Fan Return	+12V Fan